

[CONTRIBUTION FROM THE GATES CHEMICAL LABORATORY, CALIFORNIA INSTITUTE OF TECHNOLOGY, No. 265]

THE HIGH TEMPERATURE EQUILIBRIUM OF TITANIUM DIOXIDE AND CARBON WITH TITANIUM CARBIDE AND CARBON MONOXIDE

BY L. REED BRANTLEY AND ARNOLD O. BECKMAN

RECEIVED AUGUST 4, 1930

PUBLISHED OCTOBER 6, 1930

Introduction

This investigation is a continuation of the researches on high temperature equilibria which have been carried out in this Laboratory.¹ The high pressure apparatus previously used in studying the equilibria between zirconium oxide and carbon,^{1a} thorium oxide and carbon,^{1c} and aluminum oxide and carbon^{1d} was employed. The method consists in electrically heating a small graphite tube furnace which contains the solid reaction mixture, determining the temperature by an optical pyrometer, and measuring the gas pressure on a mercury manometer. The measurements described in this article include the pressures of carbon monoxide in equilibrium with the solid phases TiO_2 , TiC and C over the pressure range 0.8 to 2.0 atmospheres and the temperature range 1000 to 1150°. The composition of the solid reaction mixture was determined by x-ray powder photographs.

The authors wish to express their thanks to Dr. W. B. Hincke for his suggestions and interest in this work and to Mr. F. J. Ewing for his assistance in obtaining the x-ray photographs.

Apparatus and Procedure

The apparatus was substantially the same as that used in the previous high pressure investigations.^{1a,c,d} A more convenient furnace assembly was used, however, which had been developed by Dr. Hincke and one of us during the course of the investigation (unpublished) of the calcium oxide-carbon equilibrium. As is shown in Fig. 1A the graphite furnace A was supported by tungsten leads which were, in turn, connected through flexible copper cable to the water-cooled copper tubes B and C which were held rigidly co-linear by attachment to the heavy rod D. Electrode B was held in place by a micarta insulating support E; electrode C was held by a similar brass support F fitted with a thumbscrew H. The pyrex furnace bulb was sealed to the electrodes at G with sealing wax. A side tube with an inverted cup connection, also sealed with sealing wax, connected the furnace bulb with the manometer and auxiliary gas apparatus. Since the entire furnace was immersed in a water thermostat, it was necessary to protect the exposed sealing wax with paraffin.

To insert a furnace tube, the glass bulb was slipped over the lowered electrode C, which was then raised to allow the insertion of the furnace tube, after which thumbscrew H was tightened and the glass furnace bulb raised and sealed in position. It was found

¹ (a) Prescott, *THIS JOURNAL*, 48, 2534 (1926); (b) 50, 3327 (1928); (c) Prescott and Hincke, *ibid.*, 49, 2744; (d) 2753 (1927); (e) 50, 3228 (1928); (f) *Phys. Rev.*, 31, 130 (1928); (g) Hincke and Brantley, *THIS JOURNAL*, 52, 48 (1930).

that the sealing wax seals were gas tight even at two atmospheres' pressure and a furnace temperature of 2000°K.

The furnace tubes, Fig. 1B, were turned from Acheson graphite with a groove near each end to provide a central region of nearly uniform temperature within which the charge was held by graphite plugs. Two types of charge were used, one consisting of TiC and the other consisting of stoichiometric quantities of TiO₂ and graphite. In each case the materials were ground to pass through a 200-mesh sieve. The TiC was prepared by heating *in vacuo* an equimolar mixture of powdered titanium and graphite to a temperature (1950°K.) sufficiently high to volatilize any uncombined titanium metal. The TiO₂ and the metal were Eimer and Amend c. p. preparations.

When the charge consisted of TiC, the furnace was baked out *in vacuo* at a high temperature, after which the temperature was lowered to 1275 to 1350°K., and the heating continued for six to seven hours with carbon monoxide present at a pressure of about two atmospheres. When the charge consisted of TiO₂ and graphite, the furnace was heated *in vacuo* at a dull red heat for a few seconds. The apparatus was then filled with carbon monoxide at a pressure of about two atmospheres and the furnace heated to about 1750°K. for half an hour to drive off adsorbed oxygen. The furnace was then evacuated and refilled with fresh carbon monoxide at the desired pressure for the equilibrium measurements. It was found that under these conditions reaction mixtures were produced which gave satisfactory rates of reaction for the equilibrium measurements.

For preliminary work the furnace was heated by an alternating current from a low-voltage one-kilowatt transformer, but for the final measurements a direct current from storage batteries was used. To maintain a temperature of 1330°K. a current of about 70 amperes at 6 volts was required.

The Equilibrium Measurements

The equilibrium pressures were determined by measuring the rate of reaction (*i. e.*, the rate of change of carbon monoxide pressure) at constant temperature for different pressures of carbon monoxide. By obtaining a series of both forward and reverse rates with the same furnace charge, the equilibrium pressure was found graphically as the pressure corresponding to zero rate. Typical graphs are shown in Figs. 2 and 3. In Fig. 2 are shown the carbon monoxide pressures plotted as ordinates against the time as abscissas for six successive runs at the temperature 1278°K. with dif-

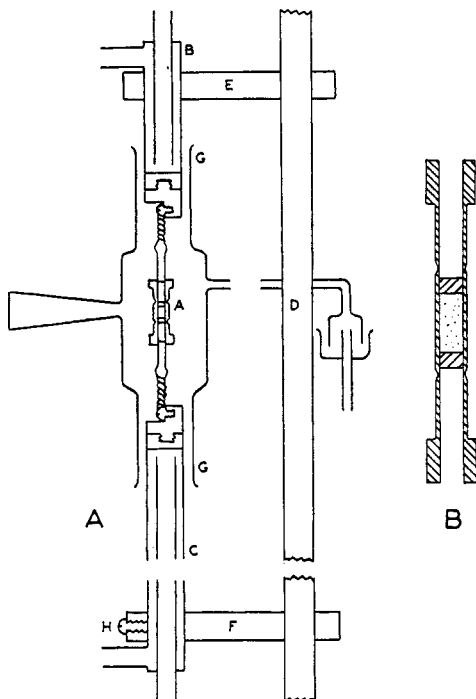

Fig. 1.—Furnace bulb and graphite furnace.

ferent initial carbon monoxide pressures. For each run the average rate of pressure change was determined, rejecting values which were obtained during the first thirty to forty minutes of the run when the system was attaining equilibrium. These six rates are shown as ordinates in Fig. 3

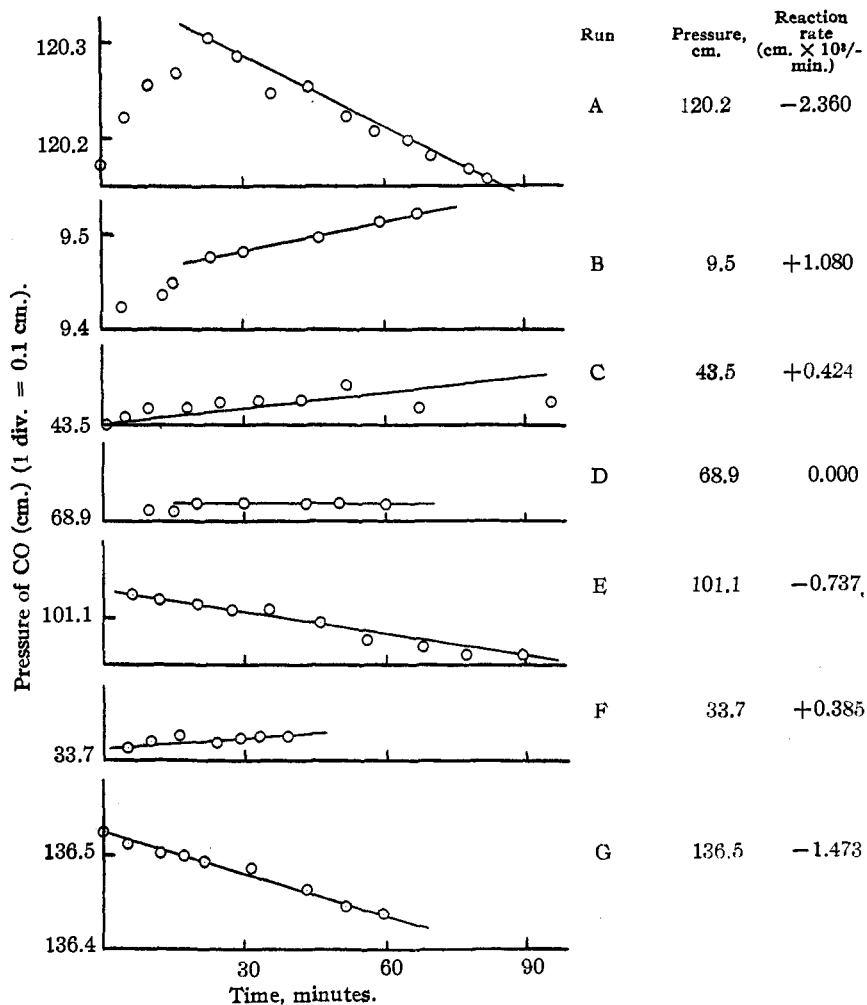

Fig. 2.—Change of pressure with time during a typical experiment (1278°K.).

with the average pressure during the run as abscissas. The intersection with the zero rate ordinate of the best straight line through these points shows the equilibrium pressure to be 60.5 cm. at this temperature.

Six sets of runs of this kind were made over the temperature range 1278 to 1428°K. and pressure range from a few centimeters to two atmospheres. In some cases the initial furnace charge consisted of TiO_2 and C, and in

other cases of TiC. The equilibrium pressures and corresponding temperatures are given in Table I, where θ is the observed temperature and T is the true temperature after corrections have been made for the transmission of the window and the emissivity of carbon as in the previous work.

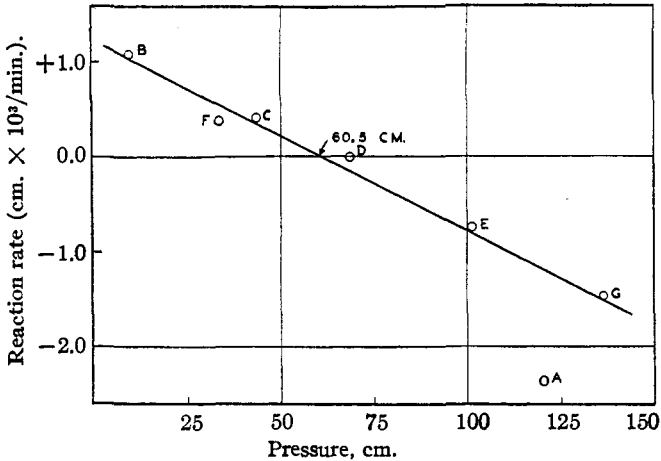

Fig. 3.—Change of reaction rate with pressure for a typical experiment (1278°K.); equilibrium pressure = 60.5 cm.

In Fig. 4 the logarithms of the equilibrium pressures are shown plotted against the reciprocals of the absolute temperatures, and it will be seen that all of the points fall upon a straight line within the experimental error.

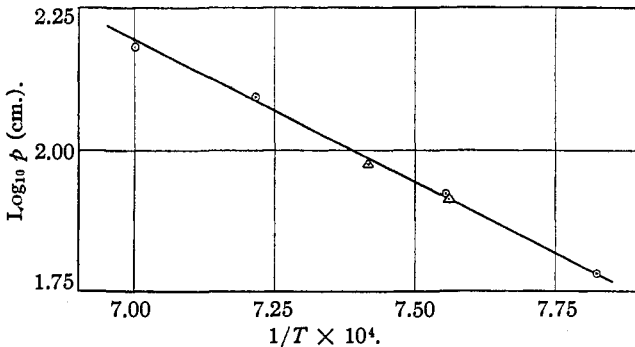

Fig. 4.—Relation between absolute temperature and equilibrium pressure of CO; circles, furnace charge initially consisted of TiO₂ + C; triangles, furnace charge initially consisted of TiC.

The relation between the equilibrium pressures and absolute temperature is given by the equation

$$\log_{10} p_{\text{atm.}} = 3.829 - 5024/T$$

A furnace charge was never used for more than two, and usually for only

one, equilibrium pressure determinations. One run was attempted at 1246°K., but the reaction rates were too slow to measure accurately.

The dissociation of carbon monoxide into carbon dioxide and carbon is appreciable in this temperature range, being approximately 0.6% at 1278°K. and 0.1% at 1428°K. It is well known, however, that equilibrium is attained only very slowly. In blank experiments, using an entirely empty graphite furnace at temperatures, with carbon monoxide pressures, and over time intervals similar to those used in the equilibrium measurements, no measurable rates were observed, showing that the carbon monoxide dissociation could be entirely neglected.

TABLE I
EQUILIBRIUM PRESSURES AND FREE ENERGIES AT VARIOUS TEMPERATURES

θ , °K.	T , °K.	$1/T \times 10^4$	p (atm.)	$\text{Log}_{10} p$ (atm.)	ΔF (cal.)
1250	1278	7.825	0.796	-0.0991	+1158
1293	1323	7.559	1.081	+0.0338	- 409
1294	1324	7.553	1.114	.0469	- 568
1318	1349	7.413	1.216	.0849	-1047
1355	1386	7.215	1.634	.2133	-2703
1393	1428	7.003	1.995	.2999	-3916

The Nature of the Solid Phases

To determine the nature of the solid phases an analytical method was attempted, but the small quantities of materials available and the lack of information regarding the chemistry of the lower oxides of titanium led to the abandonment of this method. X-Ray powder photographs were finally taken of the reaction mixtures and of the various substances, namely, TiO_2 (both the rutile and brookite modifications), TiC , graphite, Ti metal and TiO , whose presence would be suspected in the reaction mixtures. The TiO was prepared by heating in the graphite furnace to 1775°K. for half an hour *in vacuo* a mixture of finely ground TiO_2 and Ti in approximately stoichiometric proportions. The work of Billy² has shown that TiO is formed under these conditions, although perhaps there may be some uncombined TiO_2 or Ti as well. The diameters of the rings (*i. e.*, the distances between corresponding lines on either side of the position of zero deflection) obtained on the eight photographs are represented in Fig. 5. Photographs were taken of two reaction mixtures, one (Fig. 5a) in which the initial charge was TiO_2 and graphite, and one (Fig. 5b) in which the initial charge was TiC .

The results of this investigation showed that the solid phases in the reaction mixture were TiO_2 (rutile modification), TiC and graphite. Metallic titanium, the brookite modification of TiO_2 , and the lower oxide TiO were definitely shown to be absent.

² Billy, *Ann. Chim.*, 16, 23 (1921).

Thermodynamic Calculations

From the results of the x-ray investigation the equilibrium studied is undoubtedly that expressed by the equation

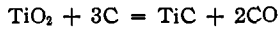

The value of ΔF , the free energy increase attending this reaction, may be derived from the thermodynamic equation $\Delta F = -RT \ln K$, where $K = p^2$. The values of ΔF corresponding to the equilibrium pressures at various temperatures are given in the last column of Table I.

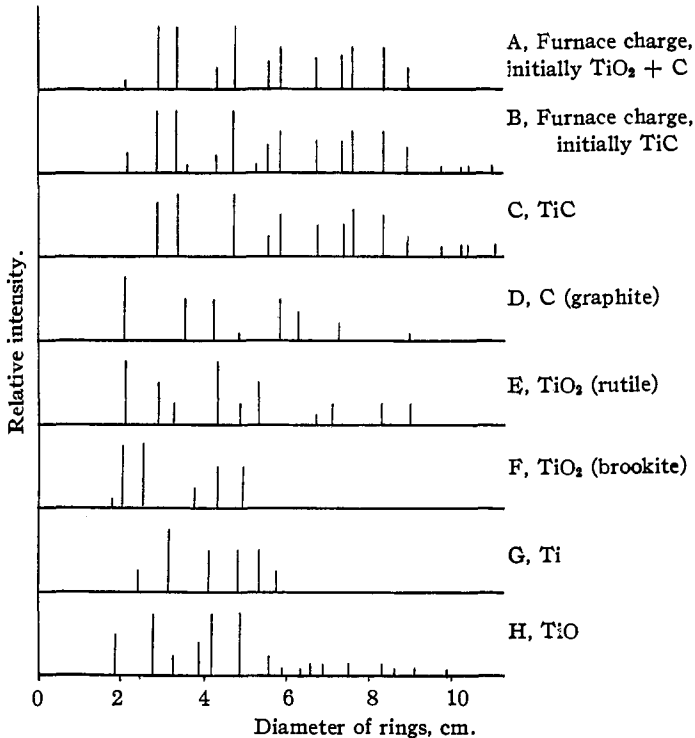

Fig. 5.—Results of x-ray powder photographs.

From the expression for $\log_{10} p$ given in the previous section, the relation

$$\Delta F = 45,930 - 35.01T$$

may be obtained for the temperature range 1278 to 1428°K. From this it follows that the increase in heat content, ΔH , is 45,930 calories. At 1312°K. the free energy is zero and the equilibrium pressure is one atmosphere.

Summary

Determinations have been made of the equilibrium pressures of carbon monoxide for the reaction

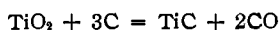

in the temperature range 1278 to 1428°K. The solid phases were identified by x-ray powder photographs.

Within this temperature range the increases in free energy and heat content that attend this reaction at one atmosphere pressure were found to be given by the expression $\Delta F = 45,930 - 35.01 T$ calories and $\Delta H = 45,930$ calories. The equilibrium pressure is one atmosphere at 1312°K.

PASADENA, CALIFORNIA

[CONTRIBUTION FROM THE RESEARCH LABORATORY OF INORGANIC CHEMISTRY,
MASSACHUSETTS INSTITUTE OF TECHNOLOGY, No. 6]

THE EFFECT OF ADDED SALTS UPON THE SOLUBILITY OF OTHER SALTS IN ETHYL ALCOHOL

BY RALPH P. SEWARD WITH WALTER C. SCHUMB

RECEIVED AUGUST 19, 1930

PUBLISHED OCTOBER 6, 1930

Introduction

The measurement of the relative solubility of a salt in a pure solvent and in the presence of other salts gives a ready measure of the change of potential or of the activity coefficient of the saturating salt. These changes should be quantitatively accounted for by any adequate theory of solutions. The inter-ionic theory of Debye and Hückel¹ has achieved considerable success in describing the properties of strong electrolytes, particularly in aqueous solutions. As the inter-ionic forces vary inversely with the dielectric constant of the solvent, we may expect a more sensitive test of the theory in the case of solvents of lower dielectric constant. The number of investigations in non-aqueous solutions by which the theory may be tested is small. Solubility measurements have been made in methyl alcohol by Williams,² in ethyl alcohol by King and Partington,³ in acetone by Robinson⁴ and by Kraus and Seward,⁵ in isopropyl alcohol by Kraus and Seward,⁵ and in ethyl alcohol-water mixtures by Hansen and Williams.⁶ These measurements indicate that marked deviations from the original Debye-Hückel approximation are found in aqueous and methyl alcohol solutions only in the case of higher valence salts. La Mer and Mason⁷ have discussed these deviations. In solvents of lower dielectric constant, however, marked deviations have been observed in the case of univalent salts even in the most dilute solutions.

The present investigation consists of the determination of the solubility

¹ Debye and Hückel, *Physik. Z.*, **24**, 185 (1923).

² Williams, *THIS JOURNAL*, **51**, 1112 (1929).

³ King and Partington, *Trans. Faraday Soc.*, **23**, 522 (1927).

⁴ Robinson, *J. Phys. Chem.*, **32**, 1089 (1928).

⁵ Kraus and Seward, *ibid.*, **32**, 1294 (1928).

⁶ Hansen and Williams, *THIS JOURNAL*, **52**, 2759 (1930).

⁷ La Mer and Mason, *ibid.*, **49**, 410 (1927).